

INSTALLATION INSTRUCTIONS

VEHICLE

FORD WINDSTAR VAN

EQUIPMENT REQUIRED: WIRE
 WIRING ACCESS LOCATION: SUV1 & SUV2
 DRILL BITS: 1/2"
 HITCH REQUIRES 1/2" PIN & CLIP
 WRENCHES: (TIGHTEN ALL FASTENERS WITH TORQUE WRENCH) 7/8

3500 LB MAX GROSS TRAILER WT
 300 LB MAX TONGUE WEIGHT
 DO NOT EXCEED TOWING VEHICLE RATINGS

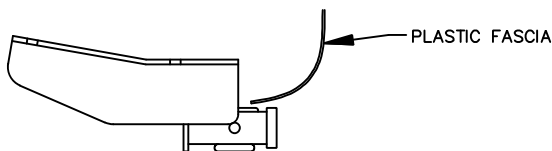

HITCH SHOWN IN PROPER POSITION

EXISTING ACCESS SLOT
 FOR FISHWIRING

1/2-13 X 1-3/4 GR5 CARRIAGE BOLT
 1/4 X 1 X 2 BLOCK
 LOCK WASHER
 NUT

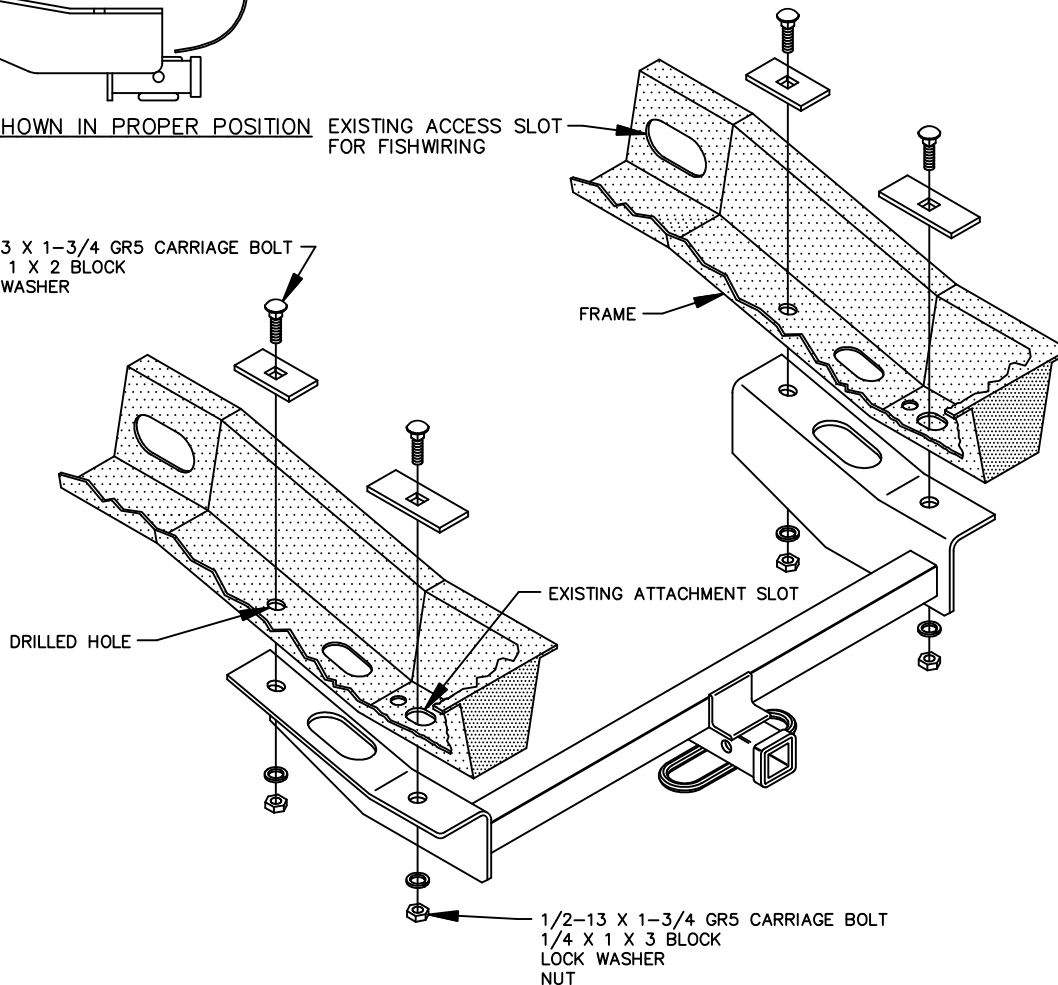

1. FISHWIRE 1/4 X 1 X 3 BLOCK AND 1/2" CARRIAGE BOLT THROUGH ACCESS SLOT IN FRAME AND DOWN THROUGH EXISTING REARWARD SLOT AS SHOWN ABOVE, EACH SIDE.
2. RAISE HITCH INTO POSITION AND FASTEN WITH LOCK WASHER AND NUT AS SHOWN ABOVE.
3. USING THE HITCH AS A TEMPLATE, DRILL TWO (2) 1/2" HOLES FOR FORWARD ATTACHMENTS AS SHOWN ABOVE.
4. FISHWIRE 1/4 X 1 X 2 BLOCK AND 1/2" CARRIAGE BOLT THROUGH ACCESS SLOT IN FRAME AND DOWN THROUGH THE DRILLED HOLE AND HITCH AS SHOWN ABOVE. BLOCK MUST LAY FLAT INSIDE FRAME.
5. INSTALL LOCK WASHERS AND NUTS AS SHOWN ABOVE.

TIGHTEN 1/2 GR5 FASTENERS TO 75 LB.-FT.

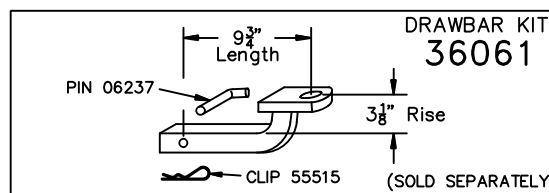

USE ONLY THE DRAWBAR SHOWN FOR CORRECT BUMPER CLEARANCE AND HEIGHT.
 DRAWBAR MUST BE USED IN THE RISE POSITION ONLY.

THIS PRODUCT COMPLIES WITH SAFETY SPECIFICATIONS AND REQUIREMENTS FOR CONNECTING DEVICES AND TOWING SYSTEMS OF THE STATE OF NEW YORK, V.E.S.C. REGULATION V-5 AND SAE J684.

APPROX WEIGHT (LB.)	FASTENER KIT
23.5	01130-884

NOTE: Check hitch frequently, making sure all fasteners and ball are properly tightened. If hitch is removed, plug all holes in trunk pan or other body panels to prevent entry of water and exhaust fumes. A hitch or ball which has been damaged should be removed and replaced. Observe safety precautions when working beneath a vehicle and wear eye protection. Follow car maker's specs for maximum trailer weight and tongue weight. Do not cut access or attachment holes with a torch.

Cequent Performance Products
 Plymouth, Michigan

PRINTED IN MEXICO