

# Installation Instructions

## GM Full Size Van

Part Numbers:  
**51023**

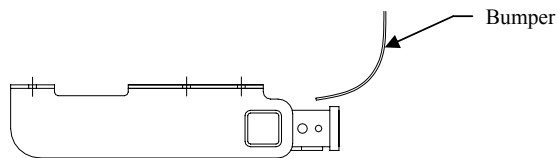

**Do Not Exceed Lower of Towing Vehicle  
Manufacturer's Rating or**

Hitch type	Max Gross Trailer WT (LB)	Max Tongue WT (LB)
Weight Distributing	<b>10,000 (4540 Kg)</b>	<b>1000 (454 Kg)</b>
Weight Carrying Ball Mount	<b>5000 (2270 Kg)</b>	<b>500 (227 Kg)</b>

**Hitch Shown In Proper Position**

**Equipment Required:**

**Fastener Kit:** 51023-051

**Wrenches:** 3/4, 7/8

**Drill Bits:** None

**Wiring Access Location:** SUV3, SUV4

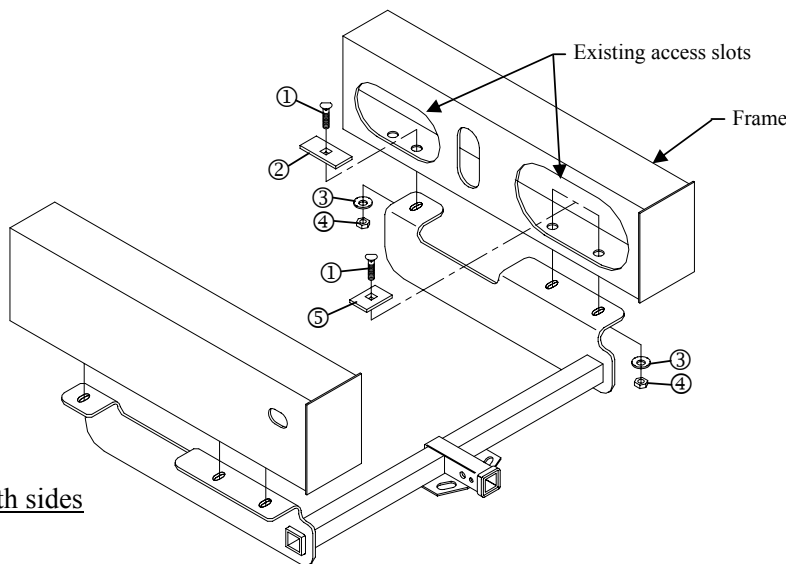

Fasteners typical both sides

①	Qty. (6)	Carriage Bolt 1/2-13 X 1.75	④	Qty. (6)	Hex Nut 1/2-13
②	Qty. (2)	Block .25 X 1.50 X 3.00	⑤	Qty. (4)	Block .25 X 1.50 X 2.00
③	Qty. (6)	Conical Washer 1/2			

1. Insert carriage bolts and blocks through existing access slots and into attachment holes as shown above.
2. Raise hitch into position and fasten with conical washers and nuts as shown above.

Tighten all 1/2-13 GR fasteners with torque wrench to 75 Lb.-Ft. (102 N\*M)

Note: check hitch frequently, making sure all fasteners and ball are properly tightened. If hitch is removed, plug all holes in trunk pan or other body panels to prevent entry of water and exhaust fumes. A hitch or ball which has been damaged should be removed and replaced. Observe safety precautions when working beneath a vehicle and wear eye protection. Do not cut access or attachment holes with a torch.

This product complies with safety specifications and requirements for connecting devices and towing systems of the state of New York, V.E.S.C. Regulation V-5 and SAE J684.