

RAIL BAR MOUNT ROOF RACKS

Product code number: **59808**

Maximum Carrying Capacity:

**110 lbs
50 kg**

Please read these instructions thoroughly before commencing installation.

ASSEMBLY OF CROSS BARS

- 1 Ensure that the Rail Bars are clean; free from dust and grease.
- 2 Pre-assemble the End Supports into Cross Bars. They are designed to be a tight fit: Use a rubber mallet if necessary (Fig.1).
- 3 Slide Top Strap into End Support (slotted end first). Making sure curled edge is facing down (Fig.2). Fit Special Bolt through the slot closest to the curled end of the Top Strap. This will allow correct Strap alignment while fitting Screw in Step 4.
- 4 Push rubber Buffer Strip back about 20mm until the screw hole appears (Fig.3). Fit Screw and tighten. Replace Buffer Strip.
- 5 Please note the Top Strap is designed to slide in and out to aid in fitting (Fig.4).

NOTE: The longer cross bar assembly is fitted to the front of the vehicle. Check labelling on the underside of the cross bars.

FITTING OF CROSS BARS TO VEHICLE

- 6 Place Cross Bars on the vehicle at the recommended positions shown along the Rail Bars (Fig. 5). Pull the Top Strap out slightly (5 to 6 mm) to allow Cross Bars to fit onto the vehicle Rail Bars (Fig.4).
- 7 Place Bottom Strap under the Top Strap with the Tab facing inward and upward (Fig. 6). While holding the Bottom Strap in place loosely fit the Special Bolt with Key provided. Fit each corner in this manner. Check that the Cross Bars are centrally located between the vehicles Rail Bars.
- 8 Gradually tighten bolts alternatively ensuring Straps are properly engaged, until even tensioning is achieved. While tightening the Bolts pull the Bottom Strap out while pushing the Top Strap in (Fig.7). **PLEASE NOTE: Do not over tighten bolts.**

FINAL CHECK

Ensure that both bars are parallel and are square to the front and rear axis of the vehicle. After loading check Bolt tightness and ensure that Straps are correctly engaged to the vehicle.

USAGE INSTRUCTIONS

Loads should be evenly distributed and secured. A number of accessories for carrying special loads is available. **Only use NON-STRETCH tie down straps.**

Any weight carried on the vehicle will adversely affect its handling particularly in cornering or in a cross wind and the vehicle should therefore be driven with increased caution.

Regularly check the tightness of the Locking Straps and the security of the load.

Be aware of the statutory requirements regarding maximum permissible projections from vehicles.

Fitting Instruction Sheet No.

59808N Issue: A
11/13/08

KIA Sportage 4/05 on

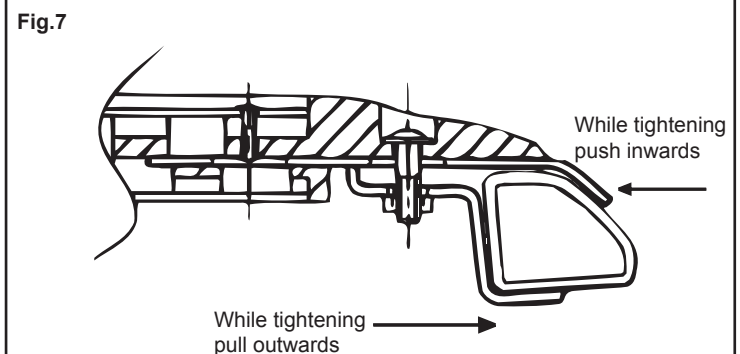
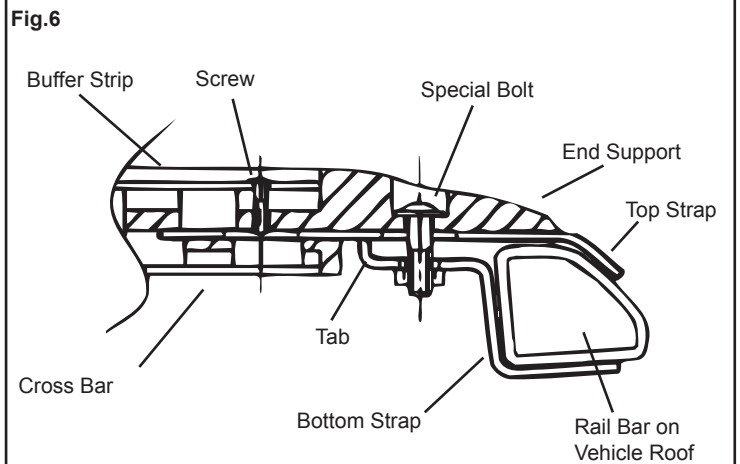
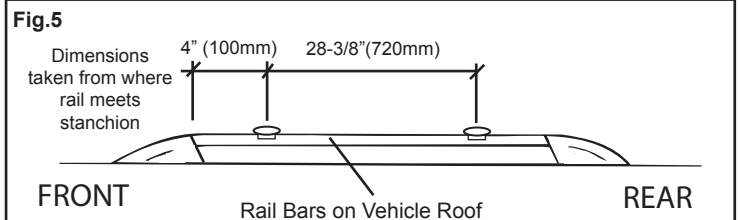
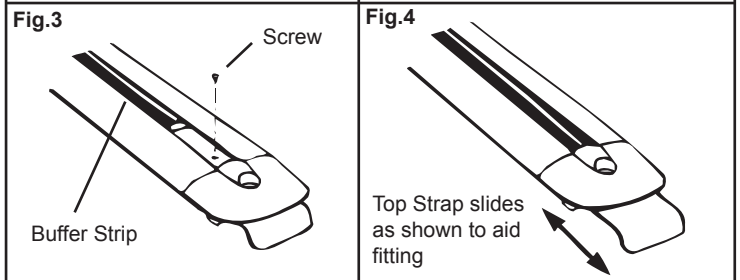
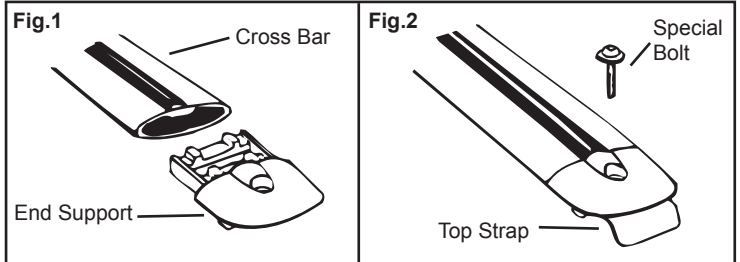

ROLA
ROOF RACKS

www.rolaproducts.com

Cequent Towing Products - Plymouth, MI
Technical Service: (888)521-0510